

R Series

4.0/4.5/5.0 T
Diesel

Options

- 2.0-5.0m duplex mast
- 2.5-5.0m full free duplex mast
- 4.3-6.5m triplex mast
- Special carriage and backrest
- Other dimension forks
- Dual drive wheel with fender
- Solid tyre
- Colored tyre(white, green)
- Cabin
- Heater and air condition
- Fire extinguisher
- Semi-suspension seat or full-suspension seat
- Dual air cleaner or special air cleaner
- Rear working light
- Customer painting
- Auxiliary hydraulic valve modules
- High-mounted exhaust system
- Middle-mounted exhaust system
- Anti-fire spark exhaust device
- Diesel exhaust gas purifier
- Radiator screen
- Sideshifter
- Integrated sideshifter
- Other attachment



CE CERTIFICATE



ISO14001: 2004



ISO9001: 2000

R Series

4.0/4.5/5.0 T
Diesel



ZHEJIANG HANGCHA ENGINEERING MACHINERY CO.,LTD.
(ZHEJIANG HANGCHA IMP. & EXP. CO.,LTD.)

www.hcforklift.com

Add: 398 Shi Qiao Road, Hangzhou 310022, P.R.China
Tel: +86-571-88135110 88126376 88135220 88125527 88130499(Ext. 8116, 8206, 8200)
Fax: +86-571-88132890 88126379
E-mail: sales@hcforklift.com

Van der Kreeft
Heftrucks



Van der Kreeft bv
Veldwade 18
3439 LE Nieuwegein

T +31 (0)30 280 55 50
F +31 (0)30 289 93 71
www.heftruck.com

Verhuur → Lease → Verkoop → Onderhoud
Heftrucks → Magazijntrucks → Hoogwerkers → Veegmachines

Zhejiang Hangcha Engineering Machinery Co., Ltd. reserves the right to make any changes without notice concerning colors, equipment, or specifications detailed in this brochure, or to discontinue individual models. The colors of trucks, delivered may differ slightly from those in brochures.

浙江杭叉工程机械股份有限公司
ZHEJIANG HANGCHA ENGINEERING MACHINERY CO.,LTD.

R series 4.0 ~ 5.0t forklift specification:

General		CPCD40		CPCD45		CPCD50		
1 Manufacture		RW5		RW5		RW5		
2 Basic model		RW19		RG24		RXW5		
3 Type		RW5		RW5		RW5		
4 Power type		Diesel		Diesel		Diesel		
5 Rated capacity	Kg	4000		4500		5000		
6 Load center	mm	500		500		500		
7 Lift height	mm	3000		3000		3000		
8 Free lift height	mm	180		180		180		
9 Fork size	LXWXT	1070 x150 x50		1070 x150 x50		1070 x150 x55		
10 Mast tilt range	F / R	6 / 12		6 / 12		6 / 12		
11 Fork overhang(Wheel center to fork face)	mm	550		550		555		
12 Rear overhang	mm	520		580		560		
13 Overall dimensions	Length to face of fork	3070		3110		3110		
	Overall width	1395		1490		1490		
	Mast lowered height	2245		2245		2395		
	Mast extended height	4170		4170		4320		
	Overhead guard height	2250		2250		2250		
18 Turning radius(outside)	mm	2890		2720		2720		
19 Min. right angle stacking aisle width (Add load length and clearance)	mm	3240		3270		3385		
20 Performance	Travel (No load)	Km / h	0 - 25	0 - 26	0 - 26	0 - 25	0 - 26	
	Lifting (Full load)	mm/sec	440	460	440	460	440	
	Lowering (Full load)	mm/sec	500	500	500	500	500	
	Max Drawbar Pull (Full load)	N	38200	35900	37200	38200	35900	37200
24 Max Gradeability (Full load)	%	20		20		20		
25 Chassis	Tyres	Front	8.25 - 15 - 14PR		300 - 15 - 14PR		300 - 15 - 14PR	
		Rear	7.00 - 12 - 12PR		7.00 - 12 - 12PR		7.00 - 12 - 12PR	
	Tread	Front	1190		1190		1190	
		Rear	1130		1130		1130	
29 Wheelbase	mm	2000		2000		2100		
30 Ground clearance	Lowest	170		170		170		
	Wheelbase center	230		230		230		
32 Self weight	Kg	6300		6500		6750		
33 Weight Distribution	Full load	Front / Rear	9000 / 1300		9625 / 1375		10125 / 1475	
	No load	Front / Rear	2800 / 3500		2820 / 3680		2820 / 3780	
34 Battery	Voltage/Capacity(20HR)	24 / 70 / 20h		24 / 70 / 20h		24 / 70 / 20h		
35 Power & Transmission	36 Engine	Model	B3.3T	TD42	4108	B3.3T	TD42	4108
		Manufacture	V / AH	COMMINS	NISSAN	LUOTUO	COMMINS	NISSAN
	Rated output / r.p.m.	kw	80 / 2200	82.5 / 2300	57 / 2200	80 / 2200	82.5 / 2300	57 / 2200
	Rated torque / r.p.m.	N.m	292 / 1600	274.4 / 1600	285 / 1400	292 / 1600	274.4 / 1600	285 / 1400
	No. of cylinder		4		4		4	
	Bore x Stroke	mm	95 x 115	96 x 96	108 x 125	95 x 115	96 x 96	108 x 125
	Emission STD		Stage 2 / Tier 2		Stage 2 / Tier 2		Stage 2 / Tier 2	
	Displacement	cc	3300		4169		4580	
	Fuel tank capacity	L	80		80		80	
	45 Transmissions	Manufacture	CHINA		CHINA		CHINA	
Type		Powershift		Powershift		Powershift		
47 Stage	FWD / RVS	2 / 1		2 / 1		2 / 1		
48 Operating pressure	For attachments	Mpa		18		18		

1. Special lifting height available (2-stage mast: 2.5m, 2.7m, 3.0m, 3.3m, 3.5m, 4m, 4.5m 3-stage mast: 4.3m, 4.5m, 4.8m, 5m, 5.5m, 6m) 2. Attachment available.
3. The specification in the table are for standard models only. For further information please contact us. 4. Specification are subject to change without notice.

F or more than 30 years, ZHEJIANG HANGCHA ENGINEERING MACHINERY CO., LTD. Has played a leading role in the manufacture and production of Chinese forklift industry. We constantly strive to develop and incorporate the latest advances in forklift design and technology to ensure that our products provide an optimum level of performance, all the time. Our new generation R series of forklifts truly exemplifies this commitment to excellence.

LOAD CHART

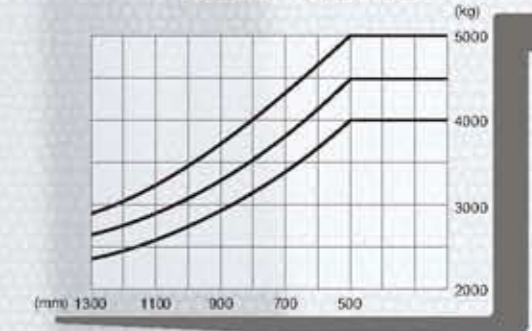

DIMENSIONS

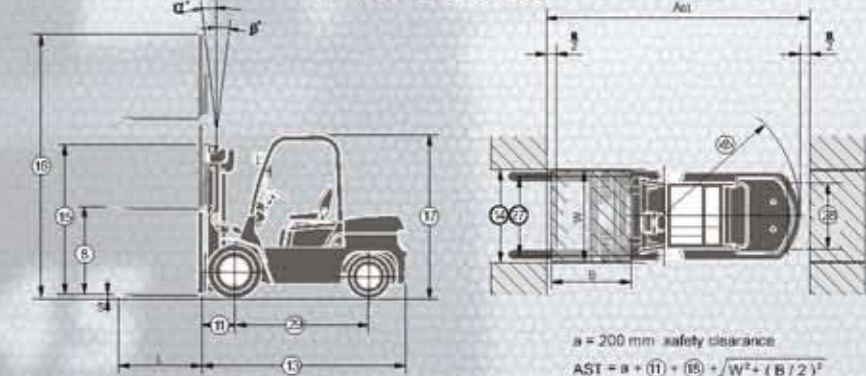

4.0 ~ 5.0t R series mast: (pneumatic)

Type	Model	Max. Fork height	Overall height								Free lift				Front Overhang		Tilt range		Capacity					
			Lowered		Extended				Without backrest		With backrest		4 / 4.5t	5t	FWD	BWD	Load capacity at 500 mm							
			4 / 4.5t	5t	Without backrest	With backrest	Without backrest	With backrest	4t	4.5t	5t	4t					4.5t	5t						
Wide view mast	R45 / 50M250	2500	1995	1995	3330	3330	3670	3865	180	180	180	180	550	555	6	12	4000	4500	5000	4000	4500	5000		
	R45 / 50M270	2700	2095	2095	3530	3530	3870	4065	160	160	160	160	550	555	6	12	4000	4500	5000	4000	4500	5000		
	R45 / 50M300	3000	2245	2245	3830	3830	4170	4365	160	160	160	160	550	555	6	12	4000	4500	5000	4000	4500	5000		
	R45 / 50M330	3300	2395	2395	4130	4130	4470	4665	160	160	160	160	550	555	6	12	4000	4500	5000	4000	4500	5000		
	R45 / 50M350	3500	2495	2495	4330	4330	4670	4865	160	160	160	160	550	555	6	12	4000	4500	5000	4000	4500	5000		
	R45 / 50M380	3800	2545	2545	4430	4430	4770	4965	160	160	160	160	550	555	6	12	4000	4500	5000	4000	4500	5000		
	R45 / 50M400	4000	2795	2795	4830	4830	5170	5365	160	160	160	160	550	555	6	12	3800	4250	4750	4000	4500	5000		
	R45 / 50M430	4300	2960	2960	5130	5130	5470	5665	160	160	160	160	550	555	6	6	3600	4000	4500	3800	4250	4750		
	R45 / 50M450	4500	3070	3070	5330	5330	5670	5865	160	160	160	160	550	555	6	6	3400	3800	4250	3600	4050	4500		
	R45 / 50M480	4800	3235	3235	5630	5630	5970	6165	160	160	160	160	550	555	6	6	3000	3350	3750	3200	3600	4000		
Wide view full free 2-stage mast	R45 / 50M500	5000	3345	3345	5830	5830	6170	6365	160	160	160	160	550	555	6	6	2800	3150	3500	3000	3400	3750		
	R45 / 50U250	2500	1978	1978	3385	3385	3670	3865	1114	1114	809	810	557	562	6	12	4000	4500	5000	4000	4500	5000		
	R45 / 50U275	2750	2100	2100	3615	3615	3920	4115	1238	1238	933	935	557	562	6	12	4000	4500	5000	4000	4500	5000		
	R45 / 50U300	3000	2226	2226	3885	3885	4170	4365	1384	1384	1055	1055	557	562	6	12	4000	4500	5000	4000	4500	5000		
Wide view full free 3-stage mast	R45 / 50U330	3300	2376	2376	4165	4165	4470	4665	1514	1514	1205	1210	557	562	6	12	4000	4500	5000	4000	4500	5000		
	R45 / 50U360	3600	2526	2526	4485	4485	4770	4965	1664	1664	1359	1360	557	562	6	12	4000	4500	5000	4000	4500	5000		
	R45 / 50N400	4000	2080	2080	4850	4850	5170	5365	1229	1222	912	915	603	615	6	12								
	R45 / 50N430	4300	2206	2205	5155	5160	5470	5665	1329	1322	1012	815	603	615	6	6	3400	3800	4250	3800	4050	4500		
	R45 / 50N450	4500	2270	2270	5385	5370	5685	5880	1395	1390	1080	883	603	615	6	6	3200	3600	4000	3400	3850	4250		
	R45 / 50N480	4800	2365	2365	5680	5680	5970	6170	1489	1482	1172	975	603	615	6	6	3000	3350	3750	3200	3600	4000		
	R45 / 50N500	5000	2435	2435	5885	5880	6170	6370	1559	1552	1242	1045	603	615	6	6	2800	3150	3500	3000	3400	3750		
	R45 / 50N550	5500	2600	2600	6355	6360	6670	6870	1724	1718	1408	1210	603	615	3	6	2250	2550	2850	2800	3100	3350		
R45 / 50N600	6000	2815	2815	6865	6870	7180	7380	1939	1932	1622	1425	603	615	3	6	1700	1950	2200	2600	2900	2950			

With sideshifter minus 200kg, with integral sideshifter minus 100kg

